

CANUSSA

MADE IN SPAIN



The new eco-design revolution

Make a difference.

Canussa is a premium eco-design accessories brand that produces with the best and most innovative materials, designed and manufactured in Spain by artisans who make each piece unique.

A hallmark? The **durability** and **resistance** of the accessories, which, in addition to being stylish, are sustainable and vegan, and maintain the same appearance from day one as time goes by.

Each Canussa accessory is filled with values and meets the highest standards of social and environmental impact validated by the renowned **B Corp** certification.

WE MERGE:

functionality and **design**

The new eco-design revolution



— The new eco-design revolution —

Fabrics

EXTERIOR

High-resistance vegan alternative to leather.

For the exterior of our accessories, we use a high-resistance microfiber that replicates the characteristics of natural cowhide leather. It is a waterproof, washable, lightweight, and highly durable material, even against chemical agents.

The microfiber is certified with the Oeko-Tex® Standard 100 class I label, the most widely used ecological label in the world, ensuring that labelled textile products have been tested for more than 300 harmful substances, affirming that it is free from harmful agents to health.



Fabrics

OUR LINING

For the interior of our accessories, we use a high-quality textile made from recycled PET with Global Recycled Standard (**GRS**) certification.

PACKAGING

Our bags are delivered with a protective bag made in Spain from recycled cotton. **All our suppliers are local.**



Range of models

TIMELESS

tote bags



designer bags



office



accessories



Tote bags

01.
basic



The new eco-design revolution



BASIC

This tote bag is the perfect combination of **comfort, lightness, and style**. It's a highly durable all-purpose bag to use every day, thanks to its large capacity and versatility. Designed with a single material and minimal seams, the Basic becomes a truly recyclable product.

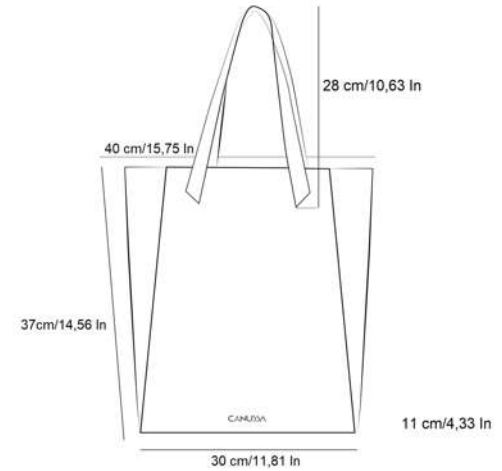

COLORS

- Camel
- Black
- Navy Blue
- Ocean Blue
- Tricolor
- Stone



02.
totissimo



The new eco-design revolution



TOTISSIMO

Our best-seller has been designed to be used in any occasion. Thanks to its **durability** and **quality**, it will always stay as good as new, and it can be folded according to the occasion. It is elegant for dinners or events, and functional for traveling or going to the office.

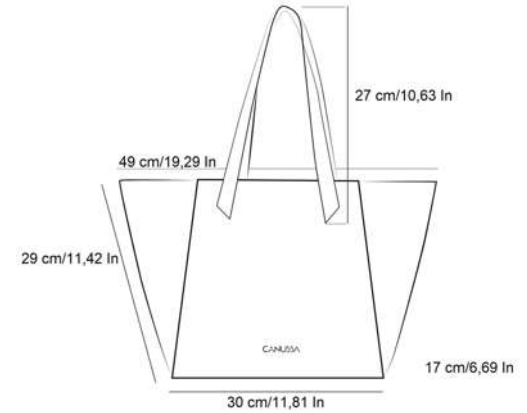

COLORS

- Camel
- Black
- Grey
- Brown
- Navy blue
- Ocean blue
- Orange
- Stone



03.
XXL



The new eco-design revolution



XXL

Minimalist, elegant, and urban, the XXL tote is the perfect accessory for those who carry their whole world with them, thanks to its large capacity and durability. For added convenience, we have added an internal zippered pocket to quickly find essential items.

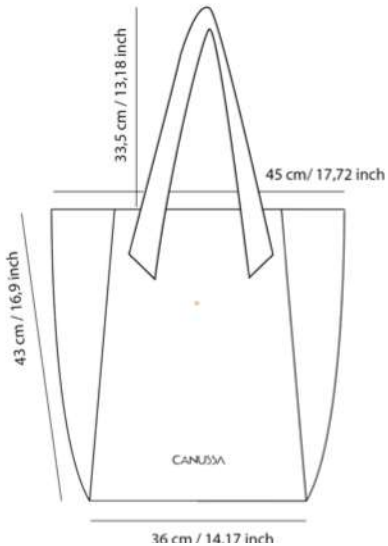

COLORS

Stone

Black

Ocean Blue

Camel



designer bags

The new eco-design revolution

01.

executive



The new eco-design revolution



EXECUTIVE

This bag has been designed to be used in day-to-day life with ample capacity and durability. It can fit all the essentials and allows you to work from anywhere without sacrificing **elegant style**. It's a bag that is not only perfect for the office but also a great accessory for travel, dinner, or a cocktail event.

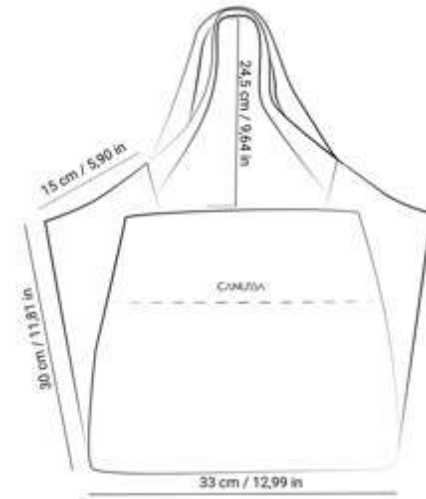

COLORS

- Camel
- Black
- Bicolor



02.
trotto



The new eco-design revolution



TROTTO

This bag has been designed for **daily use**, with capacity to carry your essentials in an organized manner, including a water bottle. It can be carried by hand or as a shoulder bag with the included strap. Additionally, thanks to its zipper, it allows for secure carrying.

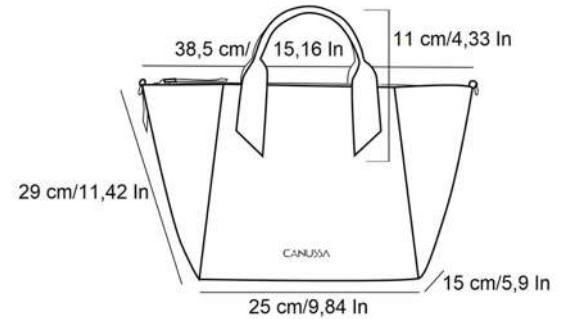

COLORS

Black

Camel

Red



03.
hybrid



The new eco-design revolution



HYBRID

The Hybrid is a small yet functional bag with compartments for eight cards, bills, coins, and a mobile phone, allowing you to have everything you need organized in one bag. It is also **versatile**, as it can be used as a handbag, crossbody bag, shoulder bag, and even as a waist bag (fanny pack) due to its two adjustable straps.

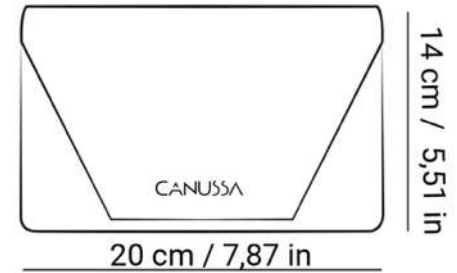

COLORS

Black

Camel

Red



office

01.

urban backpack



The new eco-design revolution



URBAN BACKPACK

An ideal backpack for **professionals** looking for an elegant and versatile solution for their travels. Designed to easily accommodate a laptop up to 15 inches and with internal compartments to keep personal belongings organized. The backpack has a front pocket for easy access.



COLORS

- Black and red
- Black and yellow



02.
airpack



The new eco-design revolution



AIRPACK

In this Canussa backpack, they have given a second life to a recycled airbag and three recovered seat belts from a scrapyard. Together with their high-resistance and water-resistant microfiber and a lining made of 100% certified recycled PET, they have created our special edition backpack. **Each model is unique!**

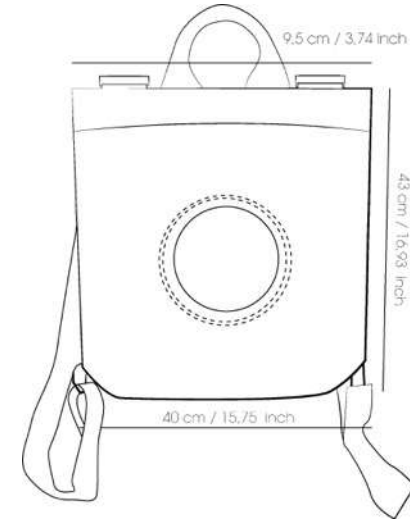

COLORS

Black and white



03.

protect case





PROTECT CASE

Complete your office look with this versatile, modern, and exclusive laptop sleeve. Resistant to light, water, and tears, this sleeve is a **smart protection** for your laptop and important documents.

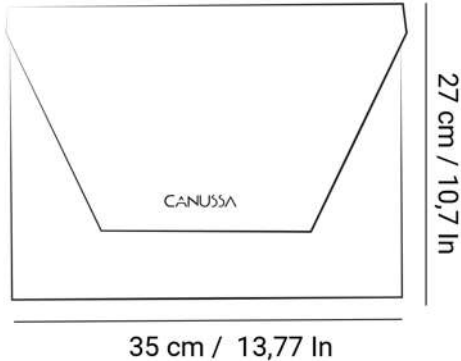

COLORS

- Black and red
- Blue and yellow
- Black and grey
- Black and yellow



accessories

01.
move



The new eco-design revolution



MOVE

This mobile phone case is versatile and modern. Suitable for the vast majority of models, it features two slots for multiple cards and a long strap to comfortably **carry it everywhere**. Resistant to light, water, and tear, this case is a smart protection for your mobile phone.

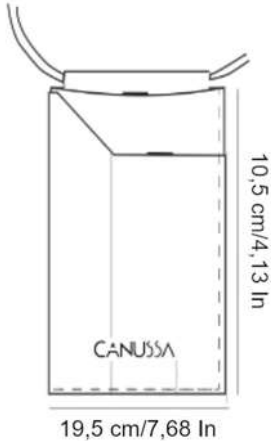

COLORS

Black and yellow



02.

Closet



The new eco-design revolution



BAG HOOK

Our Closset is a hanger made from waste and bags that have reached the end of their useful life and would normally end up in a landfill. At Canussa, we give them a second life by turning them into an **essential accessory** that can be used as a hanger or hook for any flat surface or as a padlock.

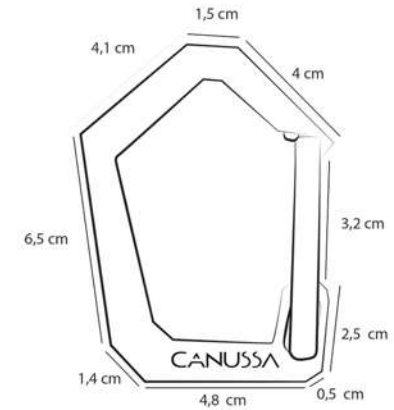

COLORS

Variable depending on waste



03.

Minimal purse





MINIMAL PURSE

This genderless wallet and cardholder has been designed to carry bills and coins along with the **most important cards**. Ideal for having the essentials at all times.

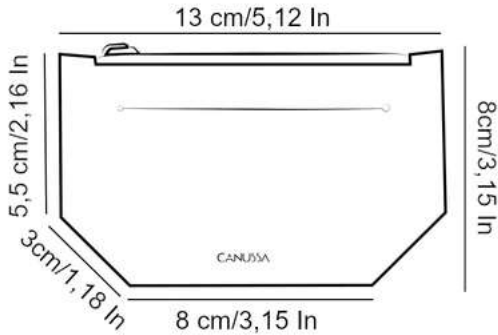

COLORES

- Negro y gris
- Negro y rojo
- Negro y amarillo

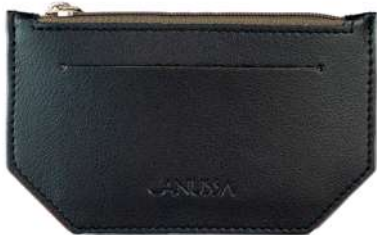

04.

Slim card holder





SLIM CARD HOLDER

Our most **minimal** cardholder can comfortably carry up to ten cards. At the front, there is space for the most frequently used cards, while the central compartment can hold the rest.

10 cm/3,94 In

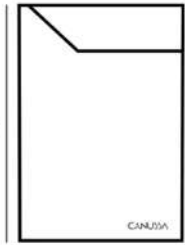

7 cm/2,75 In

COLORS

Black and red

Blue and yellow

Brown and black



05.

Slim wallet





SLIM WALLET

This wallet has been designed to comfortably carry up to six cards and numerous bills. What makes this wallet special is the combination of an **elegant design** and **functionality**.

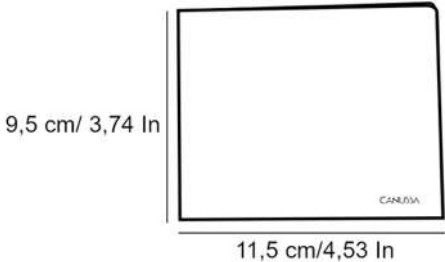

COLORS

- Black and red
- Brown
- Camel



06.

Reverse





REVERSE

This belt is the perfect combination of style and functionality. With a **reversible buckle**, it allows you to wear it in two different colours depending on the occasion, reducing consumerism by having two products in one.

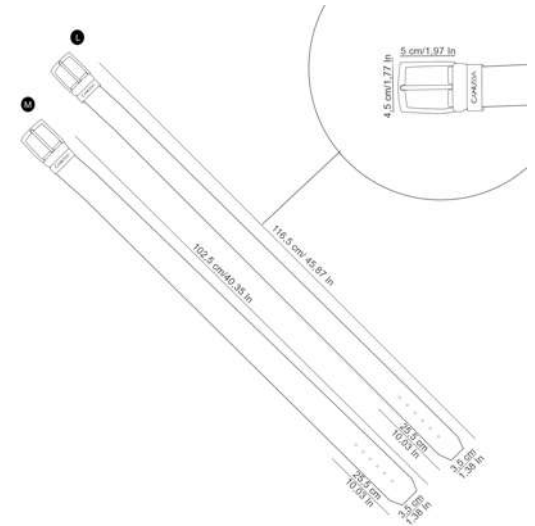

COLORS

- Black and red
- Blue and camel
- Blue and brown



07.
Go





GO

Complete your look with our Go basic reversible belt. With its versatile two-colour design, it can be easily paired with any colour. It's a **must-have** for a capsule wardrobe.

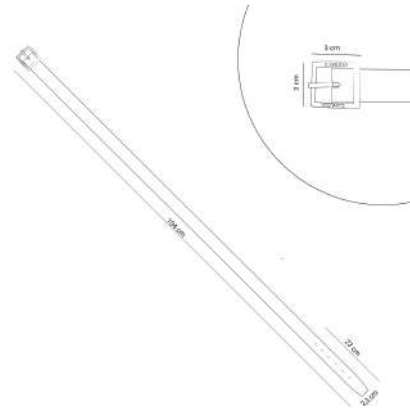

COLORS

Camel and blue

Black and red





more about

CANUSSA

The new eco-design revolution



+ 3.200

planted
trees



+ 12.000

worked **hours**
in local craft workshops



+ 5.000

kilos of
recycled **plastics**

zero
waste

Life cycle

CANUSSA PRODUCT

END OF LIFE

Regenerate
Post-consume waste recollection and transformation in new products

USE

Durable
Repair
Redistribute
Promote reuse: fashion sharing

DESIGN

Eco design strategies
Vegan and durable fabrics
Recycled materials

PRODUCTION

Made ethically in Spain
Reduce process waste
Minimal carbon footprint

DISTRIBUTION

Sustainable packaging
Sustainable logistics

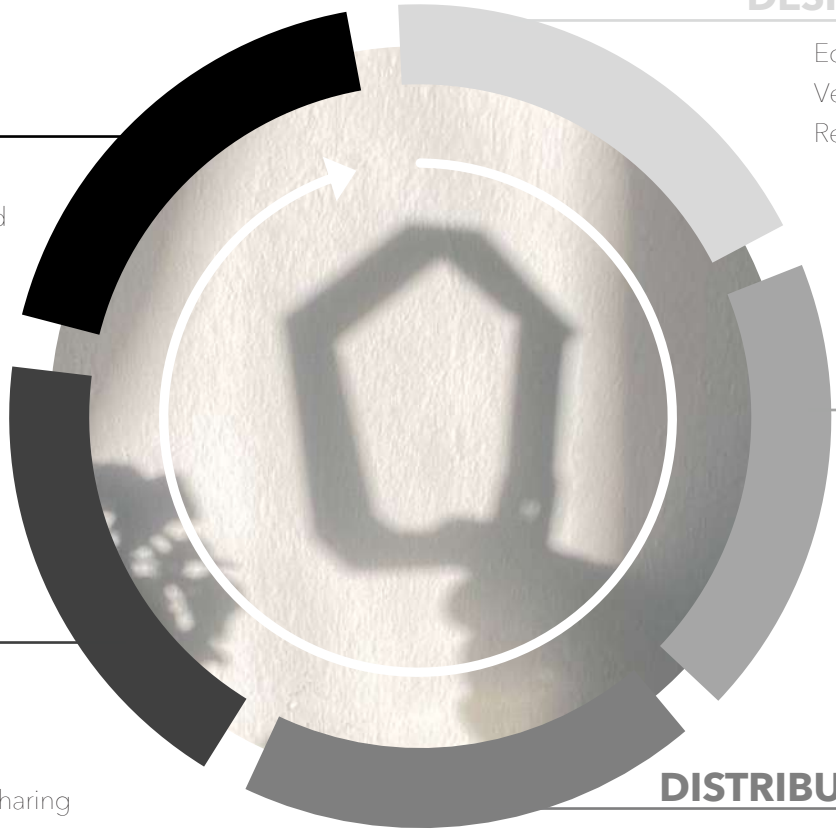

The new eco-design revolution

CANUSSA LAB

The new eco-design revolution



UP-CYCLING

This **backpack** is made of one upcycled airbag and three upcycled seatbelts recovered from the car scrapping, with our high resistant and waterproof microfiber, and with 100% recycled pet GRS certified lining.

We are working to become a **circular fashion brand** with circular products and materials, using recycled textiles where possible, extending the lifetime of our products. We are currently working on regenerating our products at the end of their life creating a hanger with these old textiles.

CIRCULAR FASHION





ECO-DESIGN

We are creating new products based on **ecodesign**. This means that we are working to make our bags ecodesigned with few seams and free of trims. This would allow them to be fully recyclable.

3D printing allows us to generate zero waste during the production process, while also bringing us closer to **on-demand** fashion, thereby reducing our carbon footprint.

3D PRINT

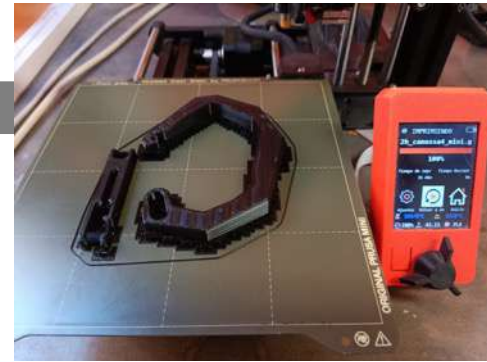

Press MENTIONS

VOGUE

"Timeless designs resorting to artisan techniques of deep-rooted tradition."

TELVA

"Their versatile and timeless bags have conquered us. But even more their philosophy."

marie claire

"Canussa has many advantages: it is waterproof, washable, lightweight, resistant, and also ecological."

rtve

"Ethical and vegan Brand fashion, produced in Spain."

InStyle

"Canussa manufactures vegan leather accessories made from recycled polyester and using artisan techniques in Spain."

LUXIDERS MAGAZINE

"Canussa's vision is to be the most recognized global brand of high-quality, stylish, vegan and sustainable accessories through circular fashion innovation and social impact."

The Guardian

"With eco-friendly fabric and non toxic dyes."

FOR ALL THE FASHION BUSINESS Drapers

"The brand received the rigorous environmental and ethical B Corp accreditation."

Our commitment to SDG's



5 GENDER
EQUALITY

Equal
opportunities
for professional
development



8 DECENT WORK AND
ECONOMIC GROWTH

Made ethically in
Spain



12 RESPONSIBLE
CONSUMPTION
AND PRODUCTION

Timeless and
durable



13 CLIMATE
ACTION

Minimal carbon
footprint



15 LIFE
ON LAND

We **plant** one
tree per each
Canussa
product sold



17 PARTNERSHIPS
FOR THE GOALS

Collaborations
with partners to
create circular
and sharing
fashion

CANUSSA

The new eco-design revolution

www.canussa.com